

PART NO.	PART NAME	QTY.
1	HPB-003	1
2	P-NC-12	1
5	Hand Pump Block	1
7	Hand Pump	1
8	DC12/24V-0.8-3500	1
9	00C0.5X047	1
10	Starter	1
13	SP-90-1 liter	1
14	Filter	1
16	Plastic Tank	1
17	HPSP-100	1

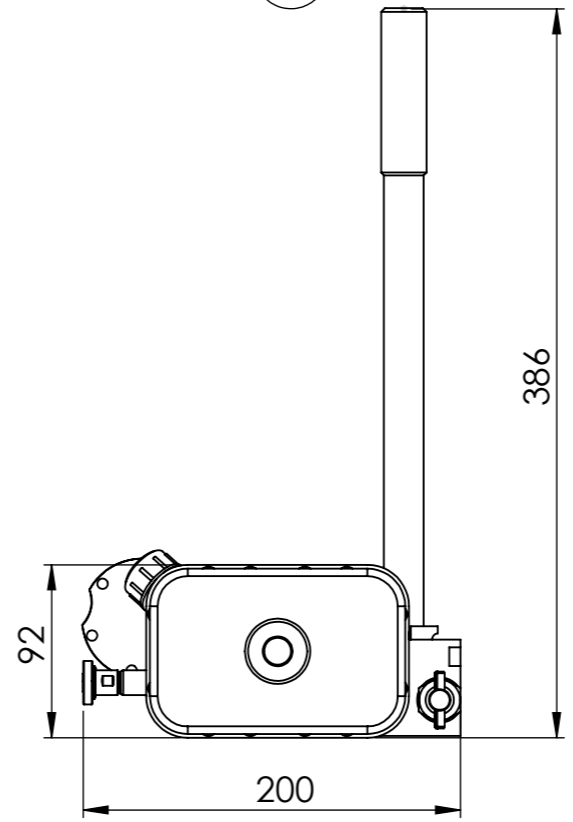

**Hydraulic Circuit**  
P = G 1/4"

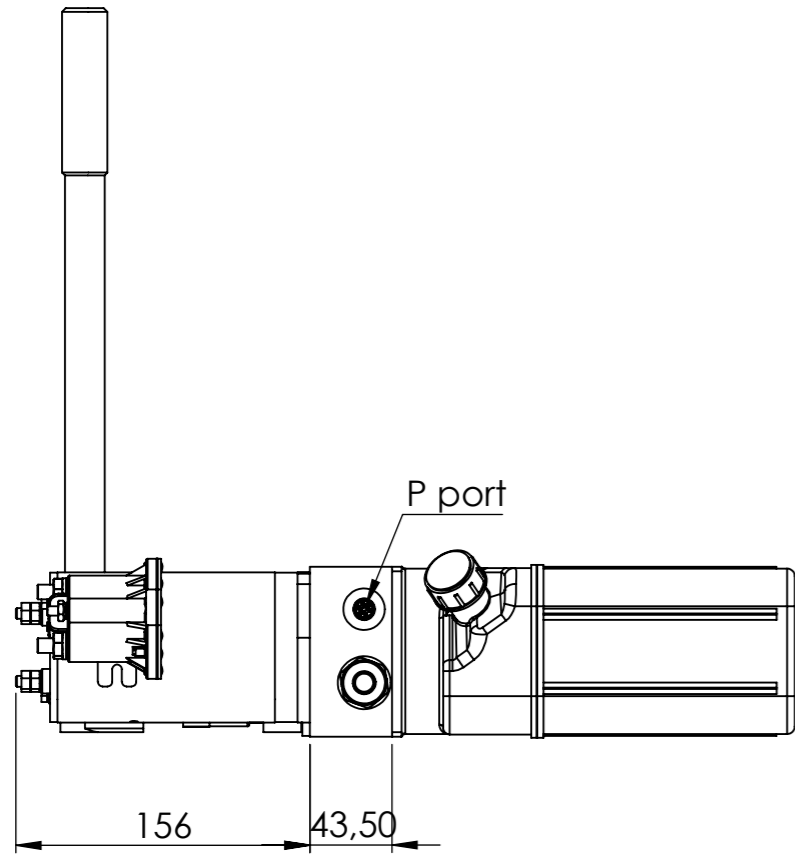
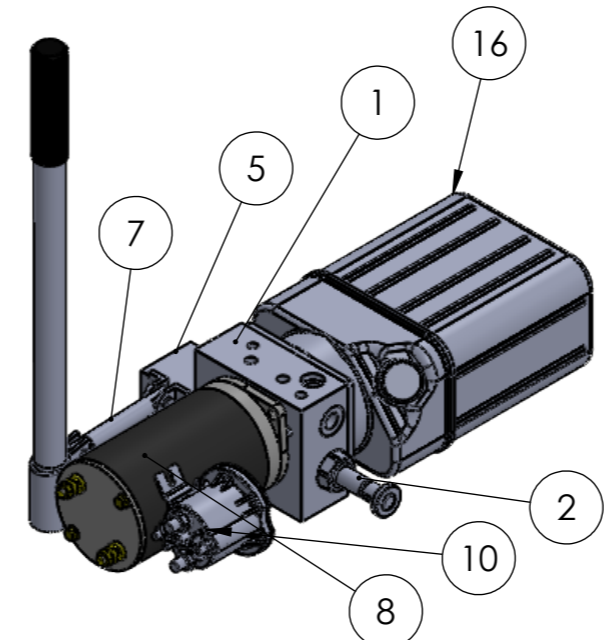
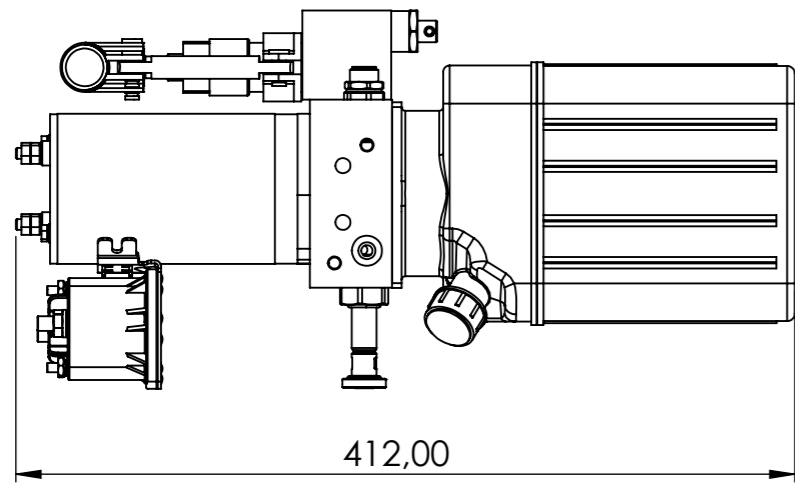
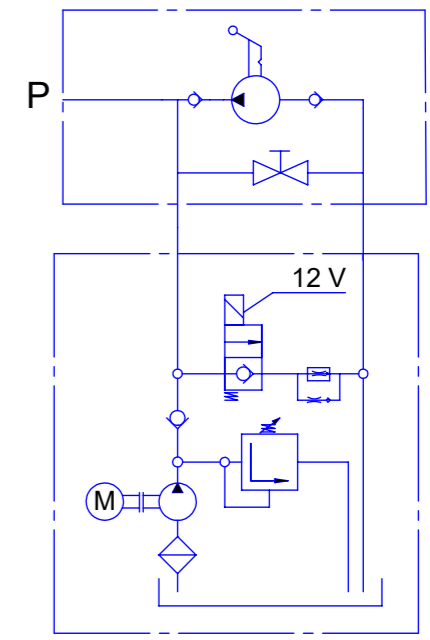

NOTES			MASS	DESIGNED BY
<b>ELECTRIC MOTOR</b>	<b>PUMP</b>	<b>OIL TANK</b>	<b>MAX PRESSURE</b>	<b>CHECKED BY</b>
POWER 0.8 kW	DISPLACEMENT 0.5cc/rev	CAPACITY 1.5 Liter	220bar	<b>DATE</b>
VOLTAGE 12/24V		TYPE Square		<b>REVISION</b>
SPEED 3500rpm		ASSEMBLY Horizontal		<b>REVISION DATE</b>
FREQUENCY		MATERIAL Plastic		

DESCRIPTION	
<b>MINI POWERPACK</b>	
SCALE: 1:4	DIMENSIONS: mm
	<b>A3</b>